

ecostore Premium 1 Door Digital Freezer, 670lt (-22/-15) - Remote (CO2)

ITEM # _____

MODEL # _____

NAME # _____

SIS # _____

AIA # _____

725239 (ESP71FFRCO2)

 1-door Freezer 670lt, -22-15°
 C, digital, AISI 304, remote,
 CO2 with valve

Short Form Specification

Item No. _____

Full door freezer entirely constructed in 304 AISI stainless steel with bottom panel in anti-corrosive material. Large digital white-digit display with cabinet temperature display and setting. HACCP-compliant control with alarms and history. Frost Watch Control to defrost only when required with automatic evaporation of defrost water. Optiflow: back to front forced air flow and removable air conveyors provides even temperature distribution and fast cooling in any conditions. Fitted with 75 mm-thick cyclopentane insulating foam. On-site reversible door features lock and door microswitch to switch off the fan when the door is opened. Hidden evaporator to guarantee higher storage capacity and less corrosion problems. Remote refrigeration unit; CO2 refrigerant with valve; ventilated operation; Internal LED light.

Main Features

- Freezer model has operating temperatures that can be adjusted from -22 to -15 °C.
- Large storage area suitable to contain 2/1 GN grids or shelves on anti-tilt runners.
- Cabinet fitted with up to 75 mm thickness of cyclopentane insulation for best insulating performance with 100% environmental protection (thermal conductivity: 0,020 W/m*K).
- Optiflow: back to front forced air flow and removable air conveyors provide even temperature distribution and fast cooling in any conditions.
- 60 mm-thick insulation covering the evaporator can be easily removed with a single operation.
- Prearranged to fit RS485 port to facilitate connection to a remote computer and integrated HACCP systems.
- Rilsan coated grids for improved protection.
- Connectivity ready for real time access to connected appliances from remote and data monitoring (requires optional accessory).
- Right hinged full door.
- Integrated RS485 port to facilitate connection to a remote computer and integrated HACCP systems.
- Large digital white-digit display with cabinet temperature display and setting, activation of turbo frost cycle (to rapidly cool warm loads) and possibility to activate manually the defrost cycle.
- Internal structure with 44 charging positions available to host grids, ensuring higher net capacity and a greater storage space.
- Possibility to select 3 different levels of humidity according with the type of food stored inside.

Construction

- Interior base with rounded corners, pressed from a single sheet.
- Lockable door.
- Remote refrigeration unit.
- Constructed from the highest quality AISI 304 Stainless steel.
- Easy access to the main components for maintenance.
- Stainless steel runners and supports easily disassembled.
- The rounded internal corners, the easily removable runners, grids and air conveyors allow for ease of cleaning and high hygiene standards.
- Anti-corrosion bottom avoids any damage that may be caused to the cabinet by aggressive detergents employed to clean the floors.
- Solenoid valve included.
- Mounted on adjustable Stainless steel feet, with castors as an option.

Sustainability

- Frost Watch Control: fully automatic defrost starts only when ice is actually building-up in the evaporator and adapt the defrosting duration to guarantee perfect ice removal while optimizing

APPROVAL: _____

energy efficiency consumption.

- Removable triple-chamber balloon magnetic gasket to improve insulation and reduce energy consumption and ease of cleaning.
- Interior LED light to save energy and for best internal visibility.
- CFC and HCFC-free insulation.
- Door switch stops the fan when door is opened to avoid cold air exiting the cell, thus saving energy.

Included Accessories

- 4 of 2/1GN grey rilsan grid with 2 runners PNC 881020

Optional Accessories

- 2 stainless steel runners for refrigerated cabinets - (Marine) PNC 880242
- Set of 8 GN1/1 PVC containers for fish PNC 880243
- Spacer for 670 lt and 1430 lt refrigerated cabinets PNC 880248
- Pedal opening for cabinets PNC 880324
- 1/1GN plastic container with false bottom PNC 880705
- Kit of 10 pairs of runners and 4 tray supports to fit pastry trays (400x600mm) PNC 881003
- 2/1GN grey rilsan grid PNC 881004
- 2/1GN aisi 304 stainless steel grid PNC 881016
- 2/1GN 304 AISI stainless steel grid with 2 runners PNC 881018
- Set of 2 stainless steel runners for 670/1430lt refrigerators and freezers PNC 881021
- 2/1GN pvc container with lid and 2 runners PNC 881039
- 2/1GN perforated shelf PNC 881042
- 1/1GN rilsan steel wire basket h=150mm PNC 881043
- 2/1GN grey rilsan basket+2 runners h=150mm PNC 881047
- Remote unit for 670lt cabinets and freezer counters - 2 and 3 compartments PNC 881123

Front

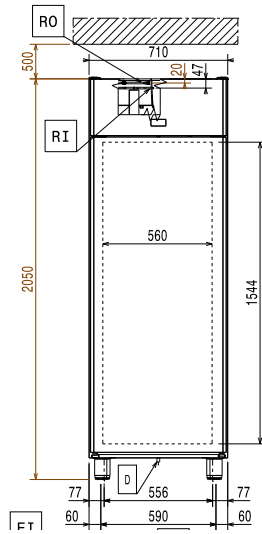

Side

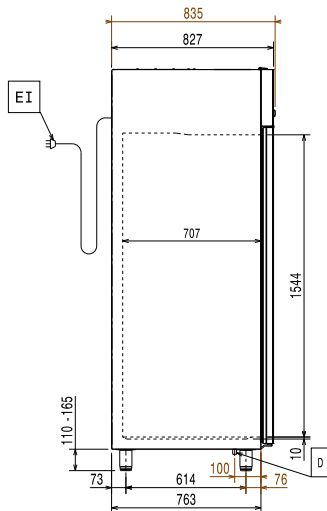

ED = Remote electrical connection RO = Refrigerant Outlet
EI = Electrical inlet (power)
RI = Refrigerant Inlet

Top

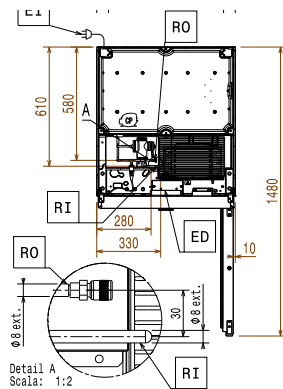

Electric

Supply voltage:
725239 (ESP71FFRCO2) 220-240 V/1 ph/50/60 Hz

Key Information:

Gross capacity: 670 lt
Door hinges: Right Side
External dimensions, Width: 710 mm
External dimensions, Depth: 835 mm
External dimensions, Depth with Doors Open: 1480 mm
External dimensions, Height: 2050 mm
Number and type of doors: 1 Full
Number and type of grids (included): 4 - GN 2/1
Type of external material: 304 AISI
Type of internal material: 304 AISI
Number of positions & pitch: 44; 30 mm

Refrigeration Data

Refrigeration power at evaporation temperature: -30 °C
Operating temperature min.: -15 °C
Refrigeration type: R744
Operating mode: Ventilated
Suggested refrigeration power: 971 W
Condition at evaporation temperature: -20 °C
Condition at condensation temperature: 55 °C
Condition at ambient temperature: 32 °C
Connection pipes (remote) - outlet: 9.5 mm
Connection pipes (remote) - inlet: 6 mm
Ref. Power calculated at a linear distance of 15 mt (piping)

*Note:

ISO Certificates

ISO Standards: ISO 9001; ISO 14001; ISO 45001; ISO 50001